



## TECHNICAL DATA SHEET

# ODEO Strobe <sup>NEW</sup>

# ODEO STROBE

Daniamant design and manufacture all of our products in line with the relevant worldwide approvals, technical specifications, current legislation and International directives.

Our mission is to achieve World class performance through partnerships with our suppliers, customers and employees, providing products and services that enhance the safety and security of our customers.

### Daniamant products cover 12 key areas:

- Lifejacket Lights
- Liferaft Lights
- Lifebuoy Lights
- Intrinsically Safe Lights
- Special Lights
- LED Flares
- Forward Looking Sonars (FLS)
- Bridge Navigational Watch Alarm System (BNWAS)
- Salinometers
- Oil Level Alarm
- Electronic Inclinometer
- Agency for a range of world-renowned safety product brands (supplied to the Danish market)

### Further Information

For further information on our products, please see our website: [www.daniamant.com](http://www.daniamant.com)

MODEL	Lithium	Alkaline
Part number - Tube pack	32-001A	32-002A
Part number - Tube pack - No Batteries		32-003A
Body Colour	Yellow	
Body Material	ABS	
LED - Colour	White	
IR Specification	830nm, 10mW/sr x 5	
Light - Output	50cd peak	
Detection Range	Minimum 3 nautical miles	
Batteries	4 x AA L91 Lithium Disulphide Cells	4 x AA Alkaline Cells
Batteries - Daniamant part number	49-115	30-119
Battery Marine Use	Recommended battery change every year	
Water tightness	Tested to IP68 & 50 meters for 1 hour	
Storage Life	5 Years	
Storage Temperature	-30 C to +60 C	-30 C to +60 C
Operating Temperature	-1 C to +30 C	-1 C to +30 C
Light - Duration	48 hours at full illumination	30 hours at full illumination
Light - Type	White flashing LED + Infra Red	
Drop Test	2 meters	
Weight - Including batteries	Lithium 150g	Alkaline 180g
Flots	Yes	
Approvals	SOLAS/MED/USCG	
- Classification Societies		
Approvals - Country	See our website for full list of Country approvals	

## Transport Specification

Transport regulations are subject to change. Please refer to the latest Product Safety Data Sheet at [www.daniamant.com](http://www.daniamant.com) for details.

## Accessories

**Neoprene Bag:** Part number: 32-126

**Velcro Strap:** Part number: 32-110

## Packing Specification

The ODEO Strobe is supplied as standard in a clear plastic tube

To minimize shipping costs, all ODEO Strobe are packed and supplied in boxes of 10 off and 25 off.

### The dimensions are:

Box of 10 off : 31 x 31 x 12 cm

Box of 25 off : 31 x 31 x 31 cm

### Approximate packed weights are:

With Batteries:

Box of 10 off : 3,5 kg

Box of 25 off : 7,5 kg

Without Batteries:

Box of 10 off : 3,0 kg

Box of 25 off : 6,5 kg

**Daniamant Ltd**  
Unit 3, The Admiral Park  
Airport Service Road  
Portsmouth, PO3 5RQ  
United Kingdom

Tel +44 23 92 67 51 00  
Fax +44 23 93 67 51 01  
sales@daniamant.com

**Daniamant A/S**  
Industrivej 24C  
3550 Slangørup  
Denmark  
  
Tel +45 47 37 38 00  
Fax +45 47 37 38 09  
orders@daniamant.com

### ODEO Strobe Outline

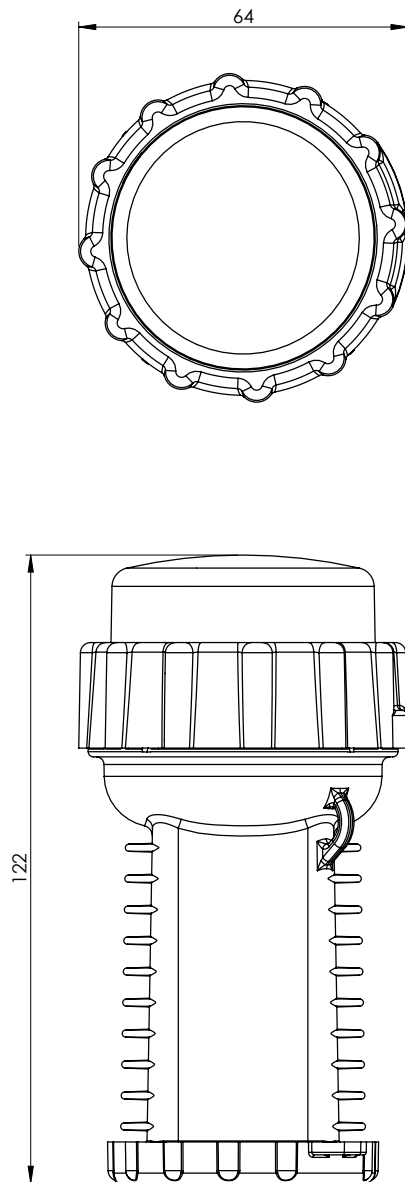

## ODEO STROBE

