

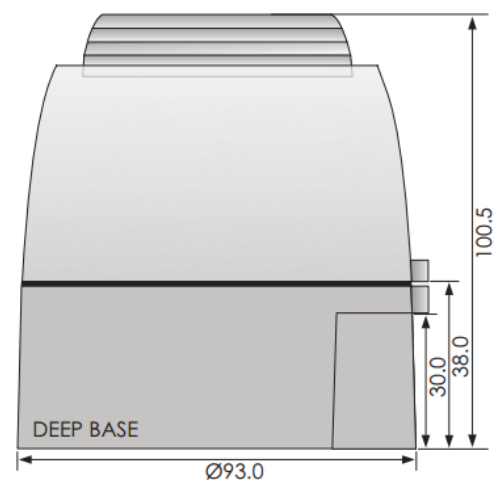

- Sound Output: 99.1dB(A)
- Light Output: 0.7 Joules
- 32 Tone, 2 Stage Alarm
- IP Rating: 21/33
- Available Lens Colours: Amber, Blue, Red, Clear, Green
- Available Voltages: 24Vdc

Sound output	101dB (24Vdc)
Alarm tones	32 (preset single tone version available)
Alarm stages	2
Volume control	10dB
Light source	LED strobe
Flash energy	0.7 Joules
Flash rate	1Hz
IP rating	21 (shallow base) 33 (deep base, powered base, U base)
Cable entry	Cut-outs (shallow base) M20 Knockouts (deep/U Base)
Terminal capacity	0.5 to 2.5mm ² cables
Operating temp.	-10°C to +55°C
Body material	ABS
Body colour options	Red, White
Lens material	Polycarbonate
Lens colour options	Amber, Blue, Clear, Green, Red
Base options	Shallow base (DC) Deep base (DC)
Unit weight	0.33Kg (Shallow base) 0.43Kg (Deep base)
Approvals	EN54-3 compliant. MED approved

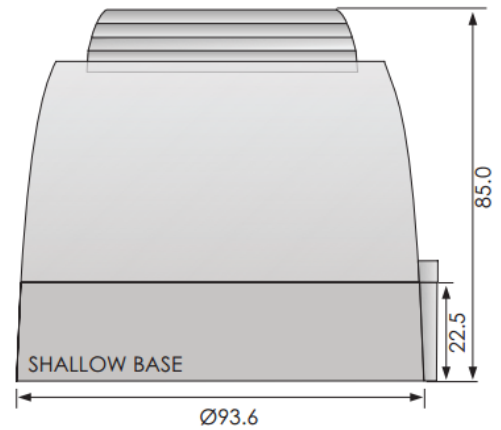
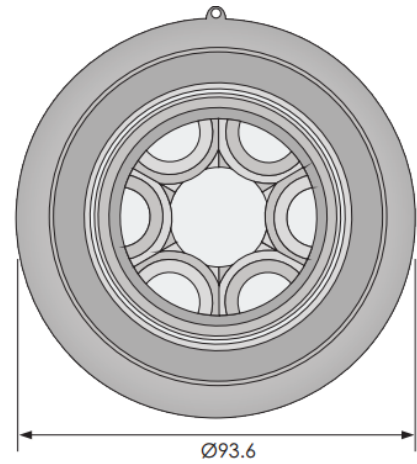

Voltage	Voltage tolerance	Current
24 Vdc	21 to 28 Vdc	34.4mA (high) 19.9mA (med) 10.8mA (low)