

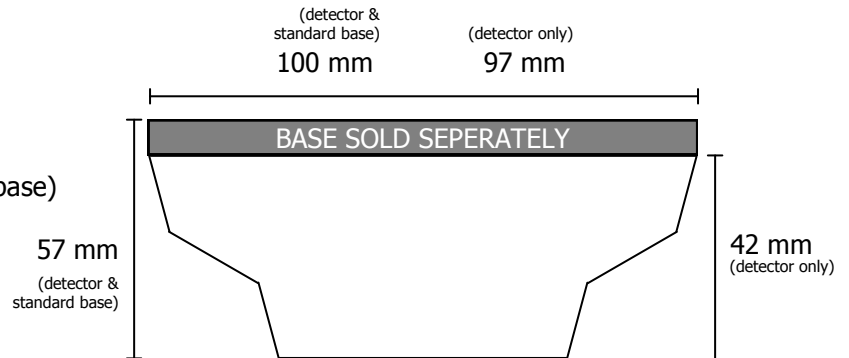

- Detector Type: Heat and Optical Smoke
- Voltage: 8.5 to 33 Vdc
- Indoor use only

<b>IP Rating</b>	23D
<b>Body Material</b>	White polycarbonate
<b>Terminal Material</b>	Nickel plated stainless steel
<b>Versions</b>	Standard Flashing LED
<b>Humidity</b>	0 to 98%
<b>Weight</b>	0.08Kg (detector) 0.14Kg (detector in base)



<b>Supply Voltage</b>	8.5 to 33 Vdc
<b>Av. Quiescent Current @ 24Vdc</b>	95µA
<b>Alarm Current @ 24Vdc</b>	40mA
<b>Alarm Current @ 12 Vdc</b>	20mA
<b>Alarm Load</b>	600 Ohms
<b>Alarm Indication</b>	Red LED
<b>Normal Operating Temperature</b>	-40 to 70°C
<b>Max Wind Continuous</b>	Not affected
<b>Remote Output (R-)</b>	1.2K Ohm connected to negative supply

The Orbis Marine Detector bases are sold separately, please see Orbis Marine Bases data sheet