



"i2"



i2-H



Fits two single standard sized 120mm x 120mm marine instruments

Features:

Innovative design allowing all helm Pods to be mounted to either 9.5" or 12" binnacle rails - *i2-H*.

1. High quality stainless steel brackets - for watertight installation, supplied with tamper proof bolts and three internal rubber bushes to allow fitting to common rail sizes
2. Custom designed seal and fasteners, increases strength and prevents overtightening of the two halves of the Pod
3. The MarinePod® i2 has the ability to be mounted to a horizontal or vertical rail
4. Incorporated Goretex® vent to prevent build up of water vapour within the Pod
5. Small internal and external indentations aid with installation and face cutting



1.

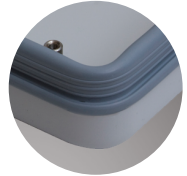

2.



3.



4.



5.

FEATURES

Pod Dimensions

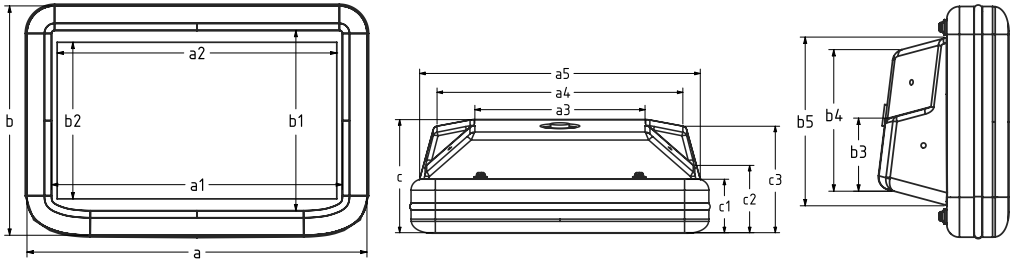

Pod Face Dimensions								
External Dimensions			Max Useable Face			Max Cut Out Area		
a	b	c	a1	b1	a2	b2		
271	183	103	232	144	223	125		
Pod Back Dimensions								
Width			Height			Depth		
a3	a4	a5	b3	b4	b5	c1	c2	c3
155	224	255	58	112	133	48	61	97

As Installed Pod Dimensions

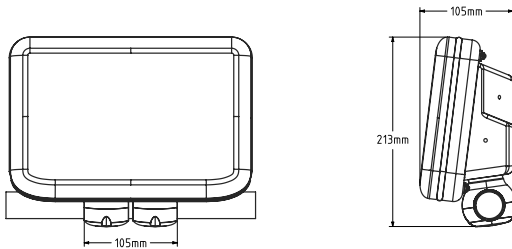

Horizontal or Vertical Rail

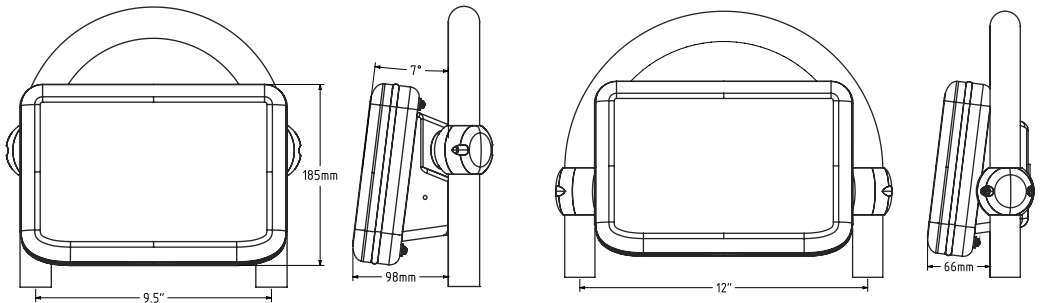

9.5" Binnacle Rail

12" Binnacle Rail

MarinePod®

MarinePod specialises in the design and manufacture of protective housings for marine electronics - "Pods". It offers the marine industry a unique approach to the common problems faced when trying to install the latest navigation or instrumentation displays on to a vessel.

Custom Design

In addition to the standard range of Pods, MarinePod can manufacture Pods with custom finishes. Choose a finish that fully complements your vessel and style. Available at an additional cost. Please call for further information.

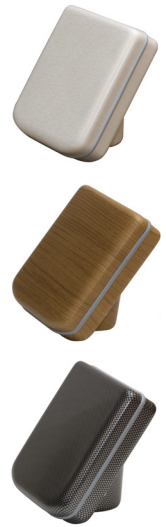

Other Products In The 2013 MarinePod Collection



t - series



c - series



w - series



x - series

NOTE: If your brand and model of electronics is not listed please call prior to ordering, or visit www.marinepod.co.uk for further information. MarinePod operates a continuous product development program and reserves the right to alter specifications without prior notice.



Made in the UK



is a registered trademark of



interformmarine
www.interform-marine.co.uk

Contact us for further information:

Tel: +44 (0) 1494 532 335

Fax: +44 (0) 1494 532 355

Email: sales@marinepod.co.uk

Web: www.marinepod.co.uk